

SF Filter for the egg liquid

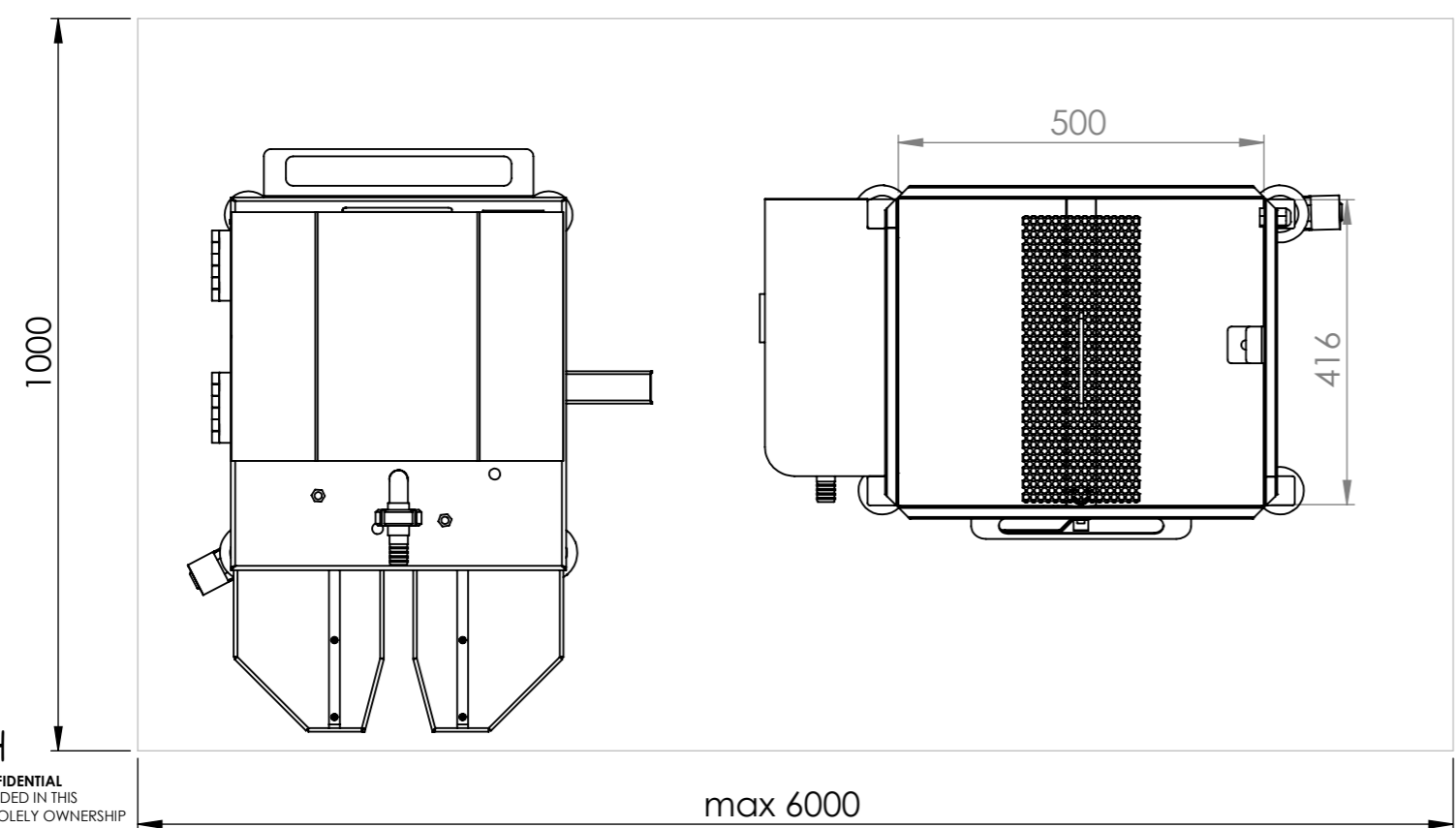
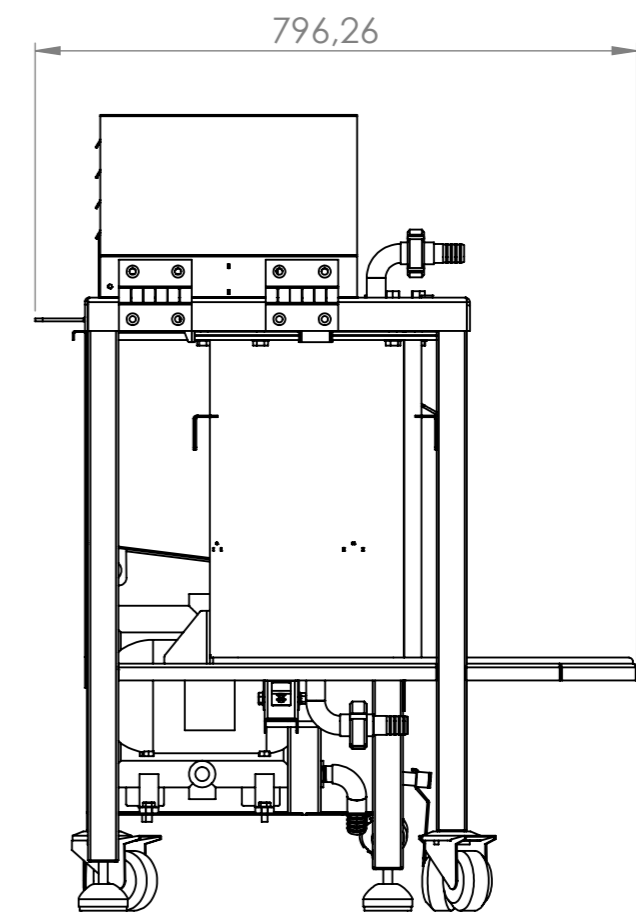
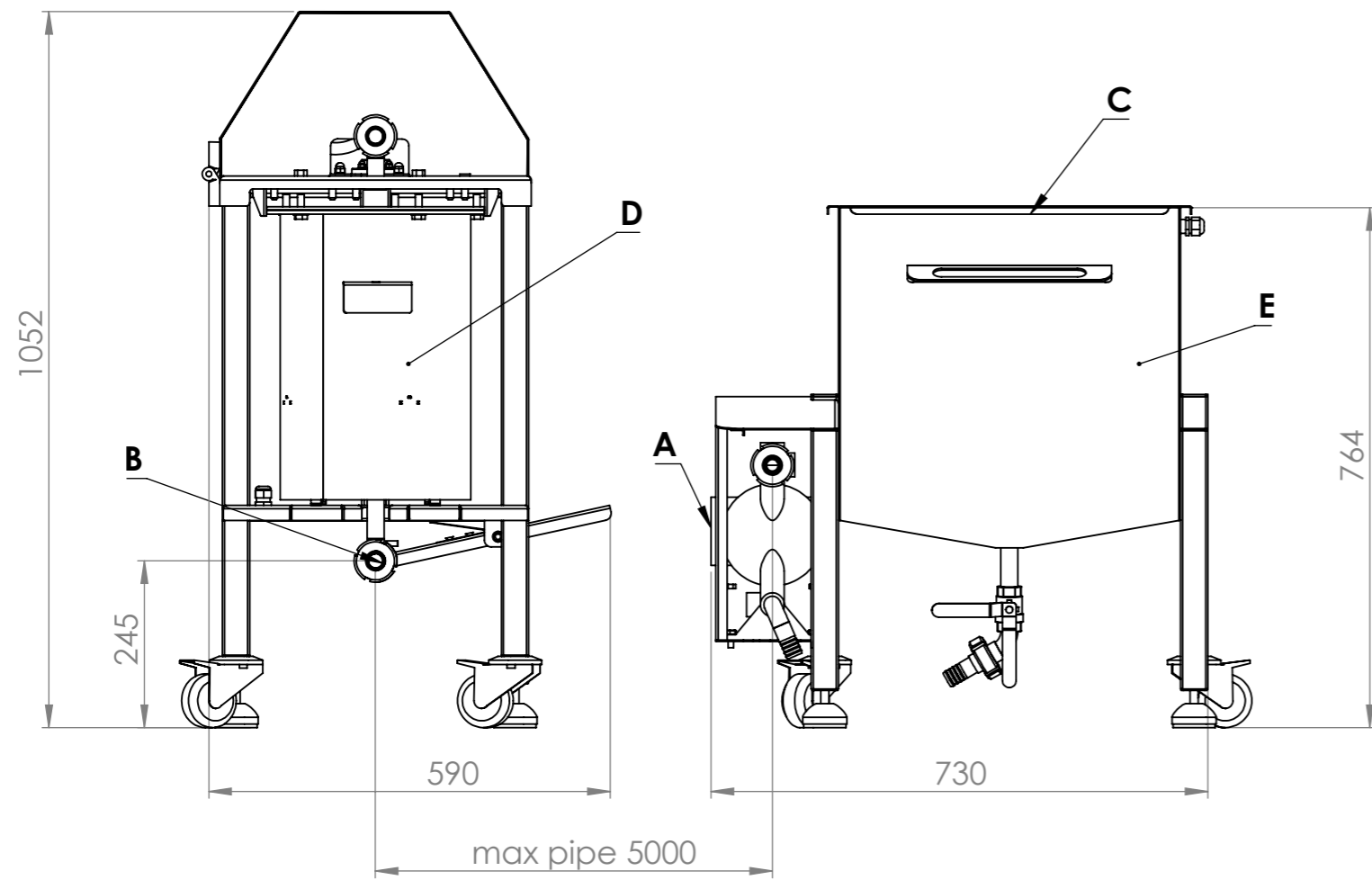

Capacity 1500l/h

- A - Air connection 1/4 inch
- B - Output clean egg mass 1" inch
- C - Egg input 1" inch
- D - Filter
- E - Egg container

Power air supply max: 6-8 bar  
 Power supply 0,5 kW 400V 3/N/PE

- to the rear side 500mm

Minimum distance to work: 1000x6000 max

**OVO-TECH**  
 RESERVED AND CONFIDENTIAL  
 INFORMATION INCLUDED IN THIS  
 THE DRAWING ARE SOLELY OWNERSHIP  
 Piotr Drapejkowski.  
 ANY REPRODUCTIONS OF PARTS OR  
 WHOLE WITHOUT WRITTEN CONDITION  
 Piotr Drapejkowski are  
 PROHIBITED.

Filter for the egg liquid SF