

## M-350 pasteurizer (pasteurization set)



### DESCRIPTION

The pasteurizer set consists of four machines: the M-350 pasteurizer, the BagInBox bag filler, the heating and cooling chiller and the shell filter. The pasteurizer process consists of four stages:

1. **HEATING:** The pasteurizer's tank is filled with liquid egg which is then automatically heated to the temperature of 66-69°C [147-154°F],
2. **PASTEURIZATION:** The liquid egg heated to the pasteurization temperature is kept in the pasteurizer's tank where it is pasteurized within a time period of 15-20 minutes which time can be adjusted on the control panel. The egg mass is continuously stirred, and the whole process is controlled by the controller and recorded in the course recorder.
3. **COOLING:** The pasteurized liquid egg is rapidly chilled to 2-6°C [36°F] with the use of ice cold water,
4. **PACKING:** The chilled egg liquid is then automatically pumped into the bag filler where the it is measured and then pumped into BagInBox plastic bags. During the pasteurization process, the liquid egg is constantly being mixed, and the whole process is supervised by a built-in controller and saved onto a recorder.



#### PHONE

SALES: +48 792 333 900

WhatsApp

WeChat



#### ONLINE

SALES: [sales@egg-breakers.com](mailto:sales@egg-breakers.com)

OFFICE: [office@egg-breakers.com](mailto:office@egg-breakers.com)



[www.egg-breakers.com](http://www.egg-breakers.com)



#### CONTACT

OVO-TECH Sp. z o.o.

Boczna 43

27-200 Starachowice

Poland

TAX ID: 664-214-74-52

EUROPEAN UNION



The machine is equipped with a semi-automatic Clean-In-Place (CIP) system which, after changing hoses configuration, automatically cleans and disinfects the machine.

Throughout the process, the egg mass is mixed. Individual stages (heating, pasteurization, cooling) are carried out automatically by the PLC and recorded in the recorder.

The machine has a semi-automatic CIP washing system that automatically cleans and disinfects the machine after changing the configuration of the hoses.

## THE DEVICE WORKING IDEA

Pasteurization of the egg mass is aimed at eliminating microbiological contamination that causes rapid spoilage of the egg mass. The technology developed by OVO-TECH sp. z o. o. allows you to obtain a product compliant with the Regulation of the European Commission (EC) No. 2073/2005 of November 15, 2005 on microbiological criteria for foodstuffs and Regulation (EC) No. 853/2004 of the European Parliament and of the Council of 29 April 2004 on hygiene in relation to food of animal origin and PN-A-86501 for egg products. The standard shelf life of the product is up to 4 weeks without deterioration of its properties. The M350 pasteurizer allows you to pasteurize from 175L [45US gal lqd] to 350L [93US gal lqd] of egg mass at a time. The duration of the process depends on the amount of pasteurized mass. It varies between 4 and 6 hours. In cooperation with the mass filter and the filler machine, it allows you to pack high quality product with maintaining hygiene standards in BAG in BOX bags type. The egg mass filter installed behind the pasteurizer tank removes any remains of eggshells that have entered the tank, which ensures the highest quality of the product and protects the filler pump against damage. The filler machine, through the precise flow measurement, allows you to fill bags from 1L [0.26US gal lqd].

## DESCRIPTION OF THE PASTEURIZATION PROCESS

The pasteurization process begins with the preparation of the egg mass. Before pasteurization, the mass must be homogenized and have a homogeneous structure. Filling the tank can be done through the connection stub if we use a pump set for filling, or by filling the tank by hand. After filling the tank to the desired volume, the operator starts the machine's work cycle. The first phase of the process consists in heating the mass to the required temperature to perform the proper pasteurization process. Proper pasteurization takes place after the batch reaches the required temperature. It consists in maintaining the pasteurization temperature for a certain period of time.



### PHONE

SALES: +48 792 333 900

WhatsApp

WeChat



### ONLINE

SALES: [sales@egg-breakers.com](mailto:sales@egg-breakers.com)

OFFICE: [office@egg-breakers.com](mailto:office@egg-breakers.com)



[www.egg-breakers.com](http://www.egg-breakers.com)



### CONTACT

OVO-TECH Sp. z o.o.

Boczna 43

27-200 Starachowice

Poland

TAX ID: 664-214-74-52

EUROPEAN UNION



Product	Temperature	Time
<b>Mixed mass</b>	66°C	20 min
<b>Whites</b>	62°C	15 min
<b>Yolks</b>	69°C	20 min

Tab. 1. Temperatures and times for different products

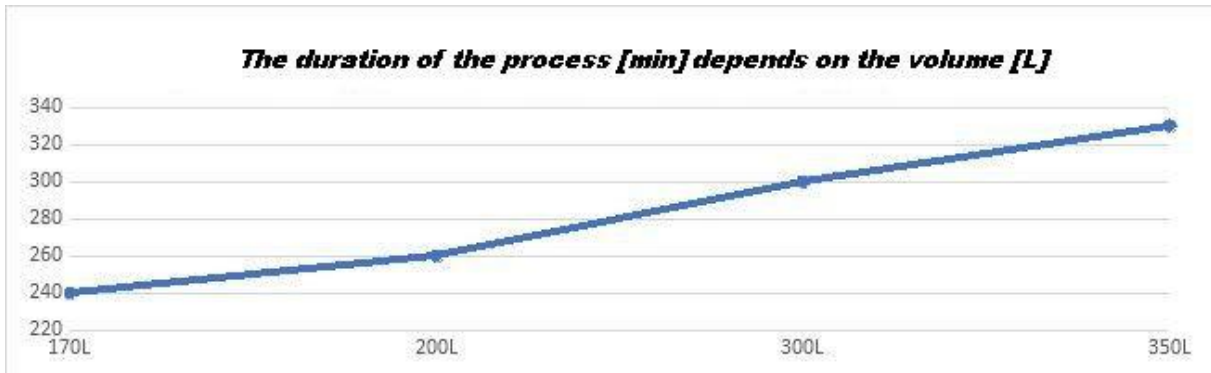

**PHONE**

SALES: +48 792 333 900

WhatsApp

WeChat



**ONLINE**

SALES: [sales@egg-breakers.com](mailto:sales@egg-breakers.com)

OFFICE: [office@egg-breakers.com](mailto:office@egg-breakers.com)



[www.egg-breakers.com](http://www.egg-breakers.com)



**CONTACT**

OVO-TECH Sp. z o.o.

Boczna 43

27-200 Starachowice

Poland

TAX ID: 664-214-74-52

EUROPEAN UNION

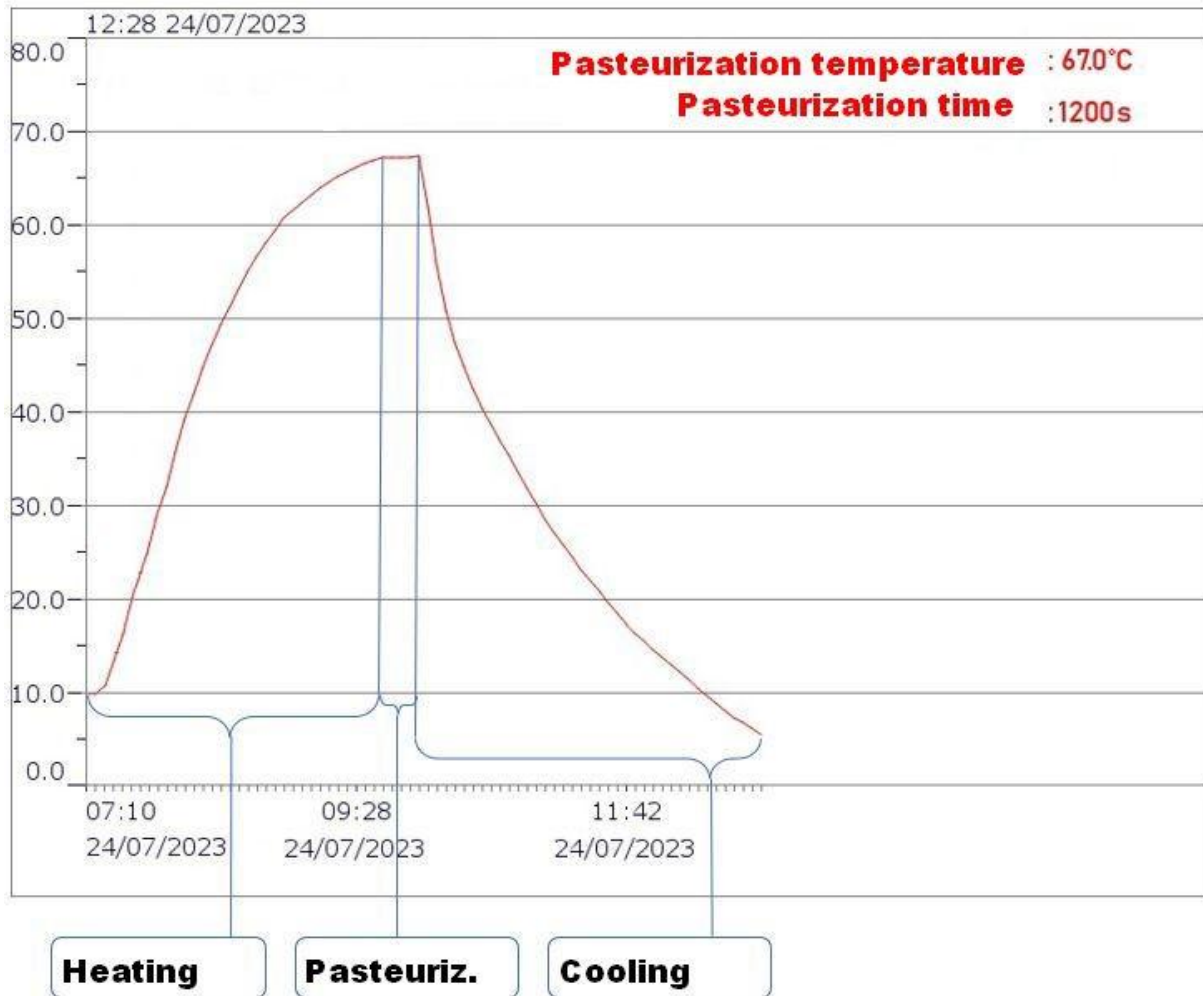

Rys. 2. Example chart of the pasteurization process

In order to maintain microbiological purity and prevent re-contamination, it is necessary to cool the mass quickly. The M350 pasteurizer provides a high cooling rate thanks to the supercooled liquid tank and the high cooling capacity of the chiller. The M350 pasteurizer can keep the set cooling temperature for a longer time after the end of the process. The cooled egg mass after the process should be poured into previously prepared BAG in BOX bags..



**PHONE**

SALES: +48 792 333 900

 WhatsApp

 WeChat



**ONLINE**

SALES: [sales@egg-breakers.com](mailto:sales@egg-breakers.com)

OFFICE: [office@egg-breakers.com](mailto:office@egg-breakers.com)



[www.egg-breakers.com](http://www.egg-breakers.com)



**CONTACT**

OVO-TECH Sp. z o.o.

Boczna 43

27-200 Starachowice

Poland

TAX ID: 664-214-74-52

EUROPEAN UNION



## DESCRIPTION OF THE FILLING PROCESS

The FM filling machine is a semi-automatic, digitally controlled egg dispenser. The supported volume of bags is 1-20L in several predefined volumes. The operator can choose one of the predefined values or can specify the desired volume value with an accuracy of 0.01L. It is also possible to operate the pourer as a manual liquid dispenser. The cooperation of a precise flow meter and a PLC controller guarantees high accuracy of the measured liquid during the filling process. The intuitive menu on the HMI touch panel enables easy change of the volume of the poured liquid. The FM filler also has a counter of filled bags for each volume. The high-performance pump built into the FM filler enables high-capacity bag filling, reducing maintenance time. The filter included in the set protects the filler elements, including the pump, by filtering out the remains of shells from the mass.

## DEVICE MAINTENANCE DESCRIPTION

The M-350 pasteurizer set and the FM filling machine have a CIP washing and disinfection system. These machines have an automated washing program that controls the parameters of the washing process. Disinfection takes place at a minimum temperature of 50°C. The basis for the correct pasteurization and filling process is the correct conduct of the disinfection process. Special attention should also be paid to the quality of the chemicals used for the washing process. OVO-TECH sp. z o. o. has selected optimal products on the market that meet quality requirements. At the client's request, OVO-TECH sp. z o. o. can deliver the necessary preparations to the client. The kit comes with detailed instructions for the cleaning and disinfection process.

## PROCESS CONTROL AND ARCHIVING

The M-350 pasteurizer has a built-in server. It collects and archives pasteurization process data, alarm history and current machine status. The web application running on the server enables remote access to the server's resources from any device with a web browser, e.g. Windows, Android, iOS platforms. Through the application, we can view the current operating status of the machine, current alarms and temperatures. It enables access to archival records of pasteurization processes and printing of a pasteurization report with a graph and process parameters. The report is saved in a universal PDF format that is easy to open on most devices.

## ADDITIONAL INFORMATION

The M350 pasteurizer, in addition to its standard operation as a pasteurizer, can also function as a refrigerator. It allows to cool down and keep the batch at the low temperature without carrying out the pasteurization process. This function is useful when mass preparation takes place in stages or is stretched over time. When there is no need to pasteurize the mass, the pasteurizer can act as a cooling container for the egg mass for an ongoing production.

ATTENTION! Working as a refrigerator does not ensure the microbiological purity of the mass, but only keeps it at a low temperature.



### PHONE

SALES: +48 792 333 900

WhatsApp

WeChat



### ONLINE

SALES: [sales@egg-breakers.com](mailto:sales@egg-breakers.com)

OFFICE: [office@egg-breakers.com](mailto:office@egg-breakers.com)



[www.egg-breakers.com](http://www.egg-breakers.com)



### CONTACT

OVO-TECH Sp. z o.o.

Boczna 43

27-200 Starachowice

Poland

TAX ID: 664-214-74-52

EUROPEAN UNION

## M-350 egg pasteurizer

## Description

**Capacity:** time of the pasteurization / cooling cycle of the product depends on the amount of raw material (175L to 350L) in the range of 4-6 hours

**Additional functions:** remote control of the process via WWW – Windows, Android, graphical and digital recording of the correctness of the pasteurization process

**Power supply:** 33 kW 400 V 3/N/PE 50/60 Hz  
33 kW 230 V 3/N/PE 50/60 Hz

**Dimensions:** 960x960x2000 mm [tank],  
1200x1200x1200 mm [chiller],  
950x650x1650 mm [FM]

**Workspace:** 5500x2200 mm

**Compressed air:** 6-8 bar, min. flow 260 l/min [FM]

**Weight:** 180 kg [tank], 230kg [chiller], 70 kg [FM]

**Water:** drinking water for washing

**Operated by:** 1 person – 3 hours of operator work per cycle of pasteurization, packaging and disinfection

**PLC Control:** pasteurization is automatic, packaging is semi-automatic, measuring the amount of egg mass – automatic, disinfection is automatic, washing is semi-automatic

**Compatibility:** PM BOX, PS-1, FS, FM

The pasteurizer set consists of four machines: the M-350 pasteurizer, the BagInBox bag filler, the heating and cooling chiller and the shell filter. The pasteurizer's tank is filled with liquid egg which is then automatically heated to the temperature of 66-69°C and rapidly chilled to 2-6°C. The desired pasteurization time can be adjusted with the control panel. The chilled egg liquid is then automatically pumped into the bag filler where it is measured and then pumped into BagInBox plastic bags. The machine is equipped with a semi-automatic Clean-In-Place (CIP) system which, after changing hoses configuration, automatically cleans and disinfects the machine. All parts of the machine which come in contact with eggs are made out of stainless steel AISI 316. The remaining parts are made out of stainless steel AISI 304



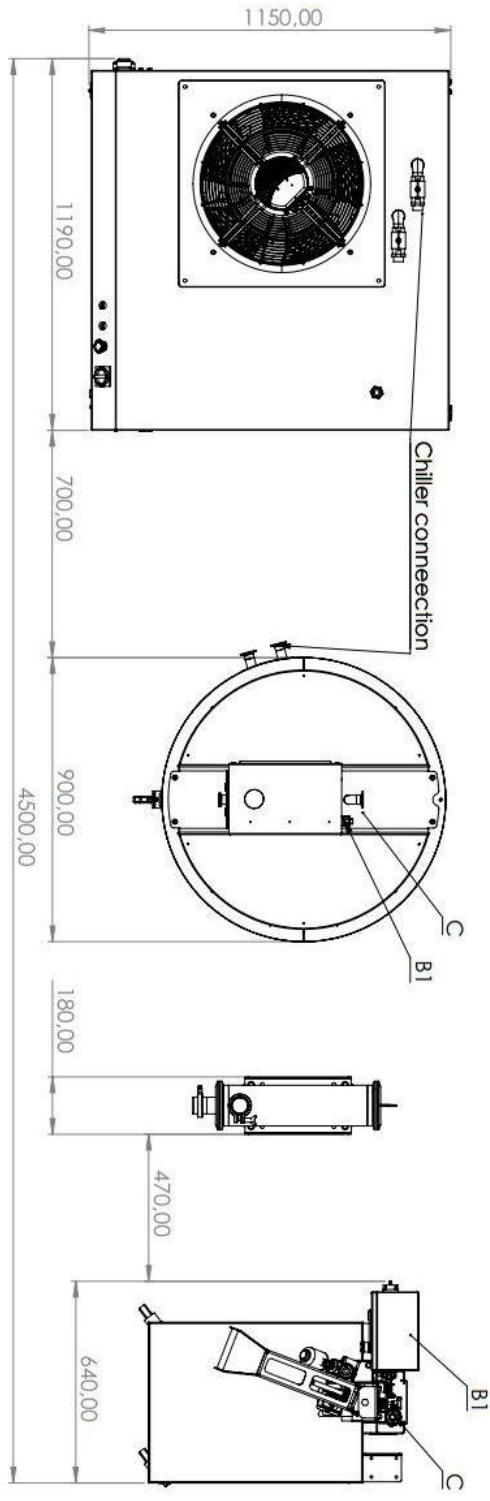
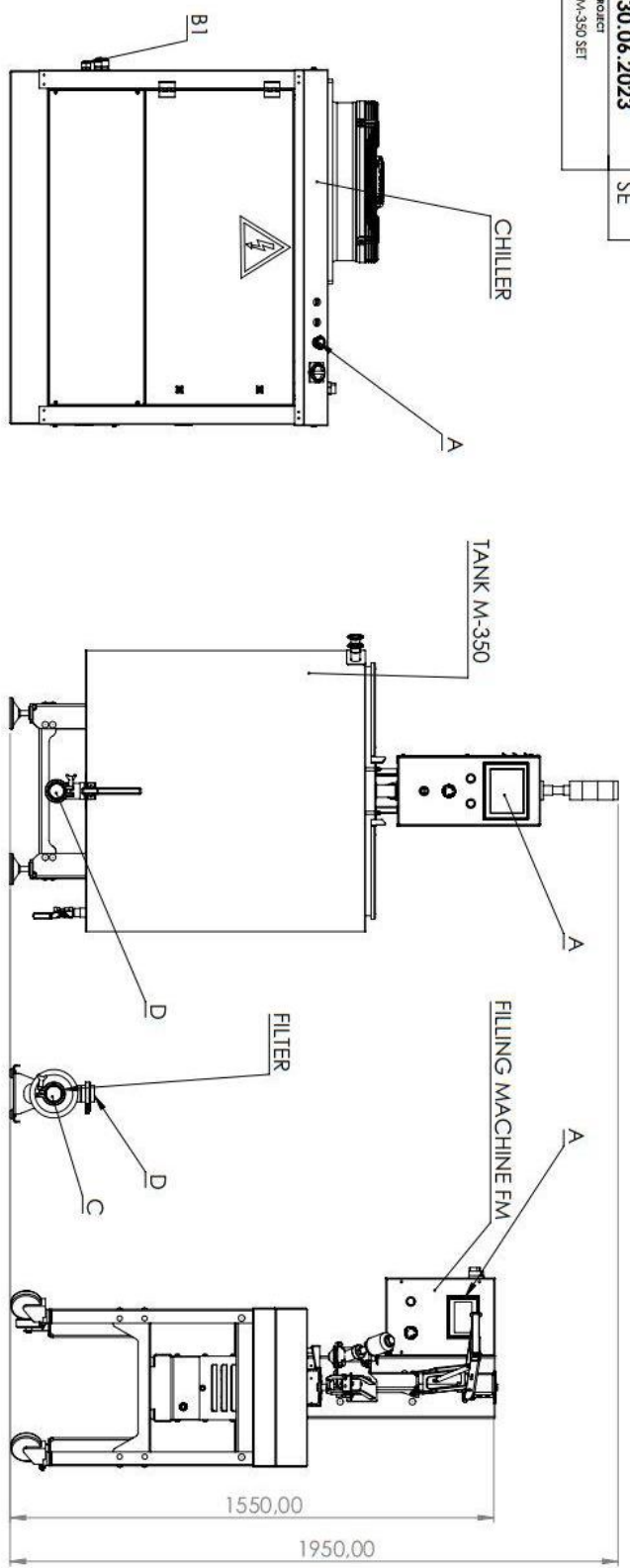

OVO TECH  
 EGG PROCESSING MACHINES

Information presented in this drawing is the sole property of OVO-TECH. Any reproduction of parts or in whole without a written permission is strictly prohibited.

M-350 SET	
Typical workplaces:	egg breaking facilities, bakeries, confectioneries, pasta making companies
Capacity:	350 L/cycle (6 head)
Power supply:	34 kW 400 V 3N/PE 50/60 Hz 34 kW 230 V 3N/PE 50/60 Hz
water connection:	Input TR-CLAMP DN25
Compressed air connection:	N/A
Minifinal workspace:	5500 x 2200 mm
Dimensions:	4500 x 2200 x 1950
Operated by:	1 person
Minifinal wall clearance:	the rear side -500 mm
Additional information:	N/A
A	control panel
B1	connectors electrical
C	liquid egg input
D	liquid egg outlet